



24L,50L DIRECT DRIVE AIR COMPRESSORS 1.5HP,2.0HP

MODEL NO: **SA2415,SA5020**

Thank you for purchasing a Sealey product. Manufactured to a high standard, this product will, if used according to these instructions, and properly maintained, give you years of trouble free performance.

IMPORTANT: PLEASE READ THESE INSTRUCTIONS CAREFULLY. NOTE THE SAFE OPERATIONAL REQUIREMENTS, WARNINGS & CAUTIONS. USE THE PRODUCT CORRECTLY AND WITH CARE FOR THE PURPOSE FOR WHICH IT IS INTENDED. FAILURE TO DO SO MAY CAUSE DAMAGE AND/OR PERSONAL INJURY AND WILL INVALIDATE THE WARRANTY. KEEP THESE INSTRUCTIONS SAFE FOR FUTURE USE.



Refer to
instruction
manual



Warning:
Automatic
startup

1. SAFETY

1.1. ELECTRICAL SAFETY

- ❑ **WARNING!** It is the user's responsibility to check the following:
Check all electrical equipment and appliances to ensure that they are safe before using. Inspect power supply leads, plugs and all electrical connections for wear and damage. Sealey recommend that an RCD (Residual Current Device) is used with all electrical products.

If the product is used in the course of business duties, it must be maintained in a safe condition and routinely PAT (Portable Appliance Test) tested.

Electrical safety information: it is important that the following information is read and understood.

- ✓ Ensure that the insulation on all cables and on the appliance is safe before connecting it to the power supply.
- ✓ Regularly inspect power supply cables and plugs for wear or damage and check all connections to ensure that they are secure.

- ✓ **Important:** Ensure that the voltage rating on the appliance suits the power supply to be used and that the plug is fitted with the correct fuse - see fuse rating in these instructions.

- ✗ **DO NOT** pull or carry the appliance by the power cable.

- ✗ **DO NOT** pull the plug from the socket by the cable.

- ✗ **DO NOT** use worn or damaged cables, plugs or connectors. Ensure that any faulty item is repaired or replaced immediately by a qualified electrician.

- ✓ This product is fitted with a BS1363/A 3 pin plug.

If the cable or plug is damaged during use, switch the electricity supply and remove from use.

Ensure that repairs are carried out by a qualified electrician.

Replace a damaged plug with a BS1363/A 3 pin plug. If in doubt contact a qualified electrician.

A) Connect the GREEN/YELLOW earth wire to the earth terminal 'E'.

B) Connect the BROWN live wire to the live terminal 'L'.

C) Connect the BLUE neutral wire to the neutral terminal 'N'.

Ensure that the cable outer sheath extends inside the cable restraint and that the restraint is tight.

Sealey recommend that repairs are carried out by a qualified electrician.

- ❑ **Warning!** The use of extension leads to connect this compressor to the mains is not recommended as the resulting voltage drop reduces motor, and therefore pump performance.

1.2. GENERAL SAFETY INSTRUCTIONS

- ✓ Familiarise yourself with the application and limitations of the compressor.

- ✓ Ensure that the compressor is in good order and condition before use. If in any doubt **DO NOT** use the unit and contact a service agent.

- ❑ **WARNING!** Compressor must only be serviced by an authorised agent. **DO NOT** tamper with, or attempt to adjust the pressure switch or the safety valve.

- ✓ Before moving or maintaining the compressor ensure that the air tank pressure has been vented.

- ✓ Only use recommended attachments and parts. Using unapproved items may be dangerous and will invalidate the warranty.

- ✓ Read the instructions for any accessory used with the compressor. Ensure that the safe working pressure of any air appliance used, exceeds the output pressure of the compressor. If using a spray gun, check that the area selected for spraying is provided with an air change system or adequate ventilation.

- ✓ Ensure that the air supply valve is turned off before disconnecting the air supply hose.

- ✓ To move the compressor use the handle only. Lift the compressor so that the front legs have enough clearance for manoeuvring but maintain the centre of gravity in front of the wheels. **DO NOT** attempt to lift or move the compressor by any other means.

- ✓ Use the compressor in a well ventilated area and ensure it is placed on a firm surface.

- ✓ Keep tools and other items away from the compressor when it is in use, and keep work area clean.

- ✓ Ensure that air hoses are not tangled, twisted or pinched.

- ✓ Keep children and unauthorised persons away from the work area.

- ✗ **DO NOT** dismantle the compressor for any reason if you are not qualified to do so. The unit must be checked by qualified personnel only.

- ✗ **DO NOT** use the compressor outdoors, or in damp, or wet, locations.

- ✗ **DO NOT** operate the compressor within the vicinity of flammable liquids, gases or solids.

- ✗ **DO NOT** touch compressor cylinder, cylinder head or pipe from head to tank as these may be hot and will remain so for some time after shut-down.

- ✗ **DO NOT** attempt to move the compressor by pulling the air hose. Only move the compressor by the handle.

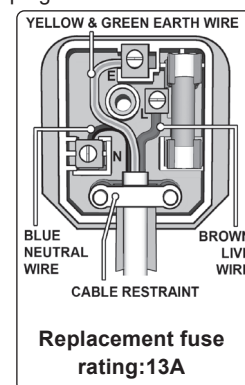

- × **DO NOT** exceed 10° incline (fig.1)
- × **DO NOT** use this product to perform a task for which it has not been designed.
- × **DO NOT** deface the certification plate attached to the end of the compressor tank.
- × **DO NOT** cover the compressor or restrict air flow around the unit whilst operating.
- ▲ **DANGER! DO NOT** direct the output jet of air towards people or animals.
- × **DO NOT** operate the compressor without an air filter.
- × **DO NOT** allow anyone to operate the compressor unless they have received full instructions.

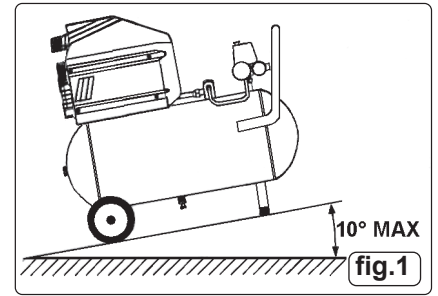

- **WARNING!** The air tank is a pressure vessel and the following safety measures apply:
 - × **DO NOT** tamper with the safety valve, **DO NOT** modify or alter the tank in any way and
 - × **DO NOT** strap anything to the tank.
 - × **DO NOT** subject the tank to impact, vibration or to heat and **DO NOT** allow contact with abrasives or corrosives.
 - ✓ Drain condensation from tank daily and inspect inside walls for corrosion every three months and have a detailed tank inspection carried out annually. The tank shell must not fall below the certified thickness at any point.
 - **WARNING!** If an electrical fuse blows, ensure it is replaced with an identical fuse type and rating. When not in use, store the compressor carefully in a safe, dry, childproof location.
- WARNING! INSPECTION OF PRESSURE TANK BOTH INSIDE AND OUT**
 Under the PRESSURE SYSTEMS SAFETY REGULATIONS 2000 it is the responsibility of the owner of the compressor to initiate a system of inspection that both defines the frequency of the inspection and appoints a person who has specific responsibility for carrying out the inspection.

2. INTRODUCTION

Aluminium head with cast iron cylinder gives added resistance to wear. Suitable for general-purpose workshop applications and pump head is directly coupled to a heavy-duty induction motor for reliable and quiet operation. Welded tank complies with latest European standards. Fitted with fully automatic pressure cut-out switch with twin gauges displaying tank and working pressures. Fitted with 3-pin plug.

3. SPECIFICATION

Model No:..... **SA2415**
 Air Displacement cfm(L/min):6(170)
 Fuse Rating:..... 13A
 Maximum Free Air Delivery cfm(L/min): 4.2(119)
 Maximum Pressure: 116psi(8bar)
 Motor Output: 1.5hp
 Nett Weight: 21kg
 Noise Level: 95dB(A)
 Outlet: Quick Release Coupling
 Phase:..... 1ph
 Plug Type:3-Pin
 Power Supply Cable Length:..... 1.8m
 Receiver Capacity: 24L
 Size (W x D x H):..... 580 x 280 x 550mm

Model No..... **SA5020**
 Air Displacement cfm(L/min):7(200)
 Fuse Rating:..... 13A
 Maximum Free Air Delivery cfm(L/min):4.8(135)
 Maximum Pressure: 116psi(8bar)
 Motor Output: 2hp
 Nett Weight: 30kg
 Noise Level: 95dB(A)
 Outlet: Quick Release Coupling
 Phase:..... 1ph
 Plug Type:3-Pin
 Power Supply Cable Length:..... 1.2m
 Receiver Capacity: 50L
 Size (W x D x H):..... 740 x 400 x 590mm

4. PREPARATION

- 4.1. Remove compressor from packaging and inspect for any missing parts or damage. If anything is found to be missing or damaged contact your supplier.
- 4.2. Save the packing material for future transportation of the compressor. It is recommended to store the packing in a safe location, at least for the period of the guarantee. Then, if necessary, it will be easier to send the compressor to the service centre.
- 4.3. Attach wheels to the compressor as shown in fig.2.
- 4.4. Confirm that the mains voltage corresponds with the voltage shown on the compressor data plate.
- 4.5. The compressor should be operated on a flat surface, or one that does not exceed 10° either transversely or longitudinally (fig.1) and should be in a position that allows good air circulation around the unit.
- 4.6. Remove the plastic transit plug from the oil filler hole and replace it with the dipstick/breather as shown in fig.4. It is a push fit, ensure that it is pushed fully home.
- 4.7. Before using the compressor check the oil level using the dipstick. If the oil is not up to the mark as shown in fig.3 it should be topped up with Sealey CPO Compressor oil.

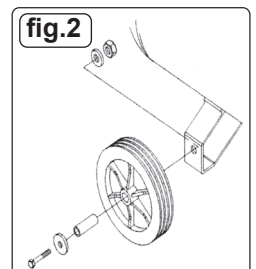

5. OPERATION

- **WARNING!** Ensure that you have read, understood and apply Section 1 safety instructions.
- NOTE:** The use of extension leads to connect this compressor to the mains is not recommended as the resulting voltage drop reduces motor, and therefore pump performance.
- NOTE:** Take care when selecting tools for use with the compressor. Air tool manufacturers normally express the volume of air required to operate a tool in cubic feet per minute (cfm). This refers to free air delivered by the compressor ('air out') which varies according to the pressure setting. Do not confuse this with the compressor displacement which is the air taken in by the compressor ('air in'). 'Air out' is always less than 'air in' due to losses within the compressor.

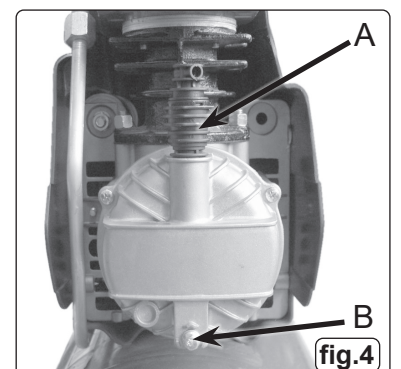

5.1. STARTING THE COMPRESSOR

5.2. PULL ON/PUSH OFF

5.3. The switch is a push/pull type as shown in fig.5.1. To turn the compressor 'ON' pull the switch knob upwards. To turn the compressor 'OFF' push the knob downwards. Check that the ON/OFF switch is in the "OFF" position, the regulator tap (fig.5.2) is closed, the output gauge (fig.5.4) must read Zero '0' bar.

5.4. Plug mains lead into mains supply and start the compressor by moving the main switch to the 'ON' position.

5.5. When starting the compressor for the first time, leave it running with no air tools connected to the air outlet (fig.5.3). Make sure that pressure in the tank rises and that the compressor stops automatically when the maximum pressure value allowed - written on the plate and shown on the gauge (fig.5.5) - is achieved.

The compressor will now operate automatically. The pressure switch stops the motor when the maximum tank pressure is reached and restarts it when the pressure falls below the minimum threshold - approx. 2 bar (29psi) less than the maximum pressure.

5.6. Stop the compressor by moving the main switch to the 'OFF' position. The compressed air inside the compressor head will flow out, making the restart easier and preventing the motor from being damaged. **DO NOT**, other than in an emergency, stop the compressor by switching off the mains socket, or by pulling the plug out, as the pressure relief will not then operate and motor damage may result upon restart.

When the compressor runs correctly and is stopped correctly there will be: (a) a whistle of compressed air when the motor stops, (b) a protracted whistle (about 20-25 seconds) when the compressor starts with no pressure in the tank.

The output pressure is regulated by the pressure regulator (fig.5.2). Lift and turn the knob clockwise to increase pressure and anticlockwise to reduce it - push knob down to lock in required position. To determine the correct working pressure for any piece of equipment check the corresponding manual. When the compressor is not being used set the regulated pressure to zero so as

NOTE: a) If the motor does not cut in and out, but runs continuously when using an air appliance, the capacity of the compressor may be too small for the equipment or tool.

b) The gauge (fig.5.5) indicates the pressure inside the main tank, NOT the pressure supplied to the air equipment. Should the pressure in the main tank exceed the pre-set switch maximum, a safety valve will activate.

❑ **WARNING!** For this reason **DO NOT** tamper with, or adjust, the switch or safety valve.

NOTE: When the compressor is not in use, it should be switched off, disconnected from the mains supply and the air drained from the tank.

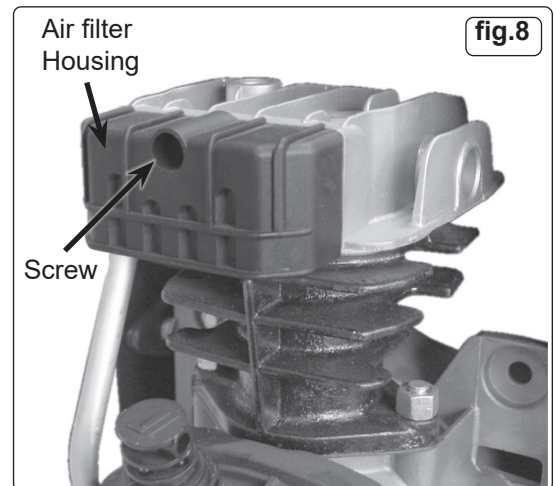
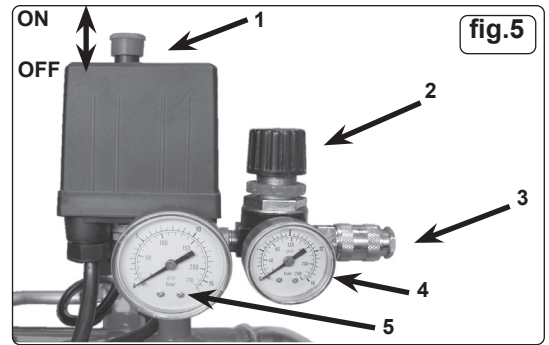

6. MAINTENANCE

In order to keep the compressor in good working condition, periodic maintenance is essential.

IMPORTANT Failure to carry out maintenance tasks may invalidate the warranty on your compressor.

❑ **WARNING** Before performing any maintenance operation, switch off the compressor, disconnect from electricity supply and release all air from the tank.

6.1. OPERATIONS TO BE CARRIED OUT AFTER THE FIRST 50 WORKING HOURS:

- Check that all bolts/nuts are tight, particularly those retaining the crankcase and cylinder head.
- Replace the lubricating oil.

6.2. Operations to be carried out weekly:

- Drain condensation by opening the valve located under the tank (fig.7). Place a container under the valve and open the valve by turning anticlockwise. b) Check oil level and, if necessary, top up.

❑ **WARNING!** Take care if there is still pressure inside the cylinder as water could flow out with considerable force. Recommended pressure 1 - 2bar max.

6.3. OPERATIONS TO BE CARRIED OUT EVERY 50 HOURS

(or more frequently, if the compressor operates in a very dusty atmosphere):

- Unscrew the air filter housing and remove the filter element (fig.8) and wash in soapy water, rinse and dry. Do not operate the compressor without the filter as foreign bodies or dust could seriously damage the pump.
- Check for oil leaks.

OPERATIONS TO BE CARRIED OUT EVERY 100 HOURS:

- Replace the lubricating oil. For oil specifications see 6.4.

Remove the dipstick/breather plug (see fig.4.A) then unscrew oil drain plug 'B', draining the oil into a container.

Drain when the compressor is hot so that oil drains rapidly and completely. Incline compressor to ensure complete drainage. Replace oil drain plug and refill through the dipstick/breather aperture. Do not overfill. Replace dipstick.

- Check the automatic cut-out at max. pressure and the automatic cut-in at 2 bar below.

❑ **WARNING!** Never mix different oils and do not use non-detergent/low quality oils as the compressor may be damaged.

❑ **WARNING!** Dispose of waste oil only in accordance with local authority requirements.

- 6.4. Operations to be carried out every 400 hours:
 a) Replace air filter. (See fig.8.)
 b) Check all tube fittings and electrical connections.

6.5. **SCHEDULED MAINTENANCE TABLE**

MAINTENANCE OPERATIONS	Weekly	50hrs	100hrs	3 Months
Drain condensation	■			
Check oil level	■			
Clean intake filter		■		
Check for oil leaks		■		
Replace oil			■	
Check cut-out			■	
General cleaning of compressor			■	
Replace air filter				■
Check tube fittings and electrical connections				■

RECOMMENDED OILS

Recommended oil for compressors, suitable for room temperatures ranging from 5°C to 25°C: SEALEY CPO compressor oil.
 Room temperature below 5°C: SAE 20 compressor oil.
 Approximate oil capacity: 0.16 litres.

IMPORTANT WARNING

Air contaminants taken into the compressor will affect optimum performance.
 Example: Body filler dust or paint overspray will clog the pump intake filter and may cause internal damage to pump/motor components. Please note that any parts damaged by any type of contamination will not be covered by warranty.

Fault	Cause	Remedy
Pressure drop in the tank.	Air leaks at connections.	Run compressor to max. pressure, switch off. Brush soap solution over connections and look for bubbles. Tighten connections showing leaks. If problem persists contact Authorised Service Agent.
Pressure switch valve leaks when compressor is idle.	Non-return valve seal defective.	Replace pressure switch.
Compressor stops and does not restart.	Power failure. Motor failure.	Check electricity supply and fuse. Contact Authorised Service Agent.
Compressor does not stop at max pressure.	Pressure switch fault.	Contact Authorised Service Agent.
Compressor does not reach max pressure.	Filter clogged. Head gasket or valve fault.	Replace filter element. Contact Authorised Service Agent.
Compressor noisy with metallic knock.	Low oil level. Bearing or piston damage.	Turn off and top up oil immediately. Contact Authorised Service Agent.



ENVIRONMENT PROTECTION

Recycle unwanted materials instead of disposing of them as waste. All tools, accessories and packaging should be sorted, taken to a recycling centre and disposed of in a manner which is compatible with the environment. When the product becomes completely unserviceable and requires disposal, drain any fluids (if applicable) into approved containers and dispose of the product and fluids according to local regulations.



WEEE REGULATIONS

Dispose of this product at the end of its working life in compliance with the EU Directive on Waste Electrical and Electronic Equipment (WEEE). When the product is no longer required, it must be disposed of in an environmentally protective way. Contact your local solid waste authority for recycling information.

Note: It is our policy to continually improve products and as such we reserve the right to alter data, specifications and component parts without prior notice.

Important: No Liability is accepted for incorrect use of this product.

Warranty: Guarantee is 12 months from purchase date, proof of which is required for any claim.

Sealey Group, Kempson Way, Suffolk Business Park, Bury St Edmunds, Suffolk. IP32 7AR

01284 757500

sales@sealey.co.uk

www.sealey.co.uk